

Accelerating Research in Brain Science and Neurodegenerative Diseases: CLARA Testbed

Kateřina Slaninová, Jan Martinovič, Vít Vondrák

IT4Innovations National Supercomputing Center, VSB - Technical University of Ostrava, Czech Republic

CLARA Center for Artificial Intelligence

The Center for Learning, Artificial Intelligence, and Advanced Research represents a pioneering interdisciplinary **Center of Excellence** — the first of its kind in Central and Eastern Europe. It was established to advance the development of next-generation **artificial intelligence, machine learning, and quantum-enabled supercomputing technologies**. To support this mission, CLARA integrates high-performance supercomputing infrastructure, advanced AI/ML model development environments, and emerging quantum computing systems into a unified computational ecosystem.

Goals

- Accelerate research on neurodegenerative disorders,
- Particular focus on Alzheimer's disease,
- Integration and analysis of large-scale biological and clinical datasets,
- State-of-the-art computational methodologies.

LEXIS Platform for Federated Access to QC/HPC/AI and Data

The CLARA Testbed leverages strategy and technology of the LEXIS Platform for data and compute federation.

- **Single-sign-on access** for running compute jobs,
- **HEAppE middleware** for compute access enables HPC resources as a service to client applications and their users,
- Data federation utilising the **iRODS (integrated Rule-Oriented Data System) middleware**,
- Usage of the **LEXIS Platform** for data management and workflow submission.

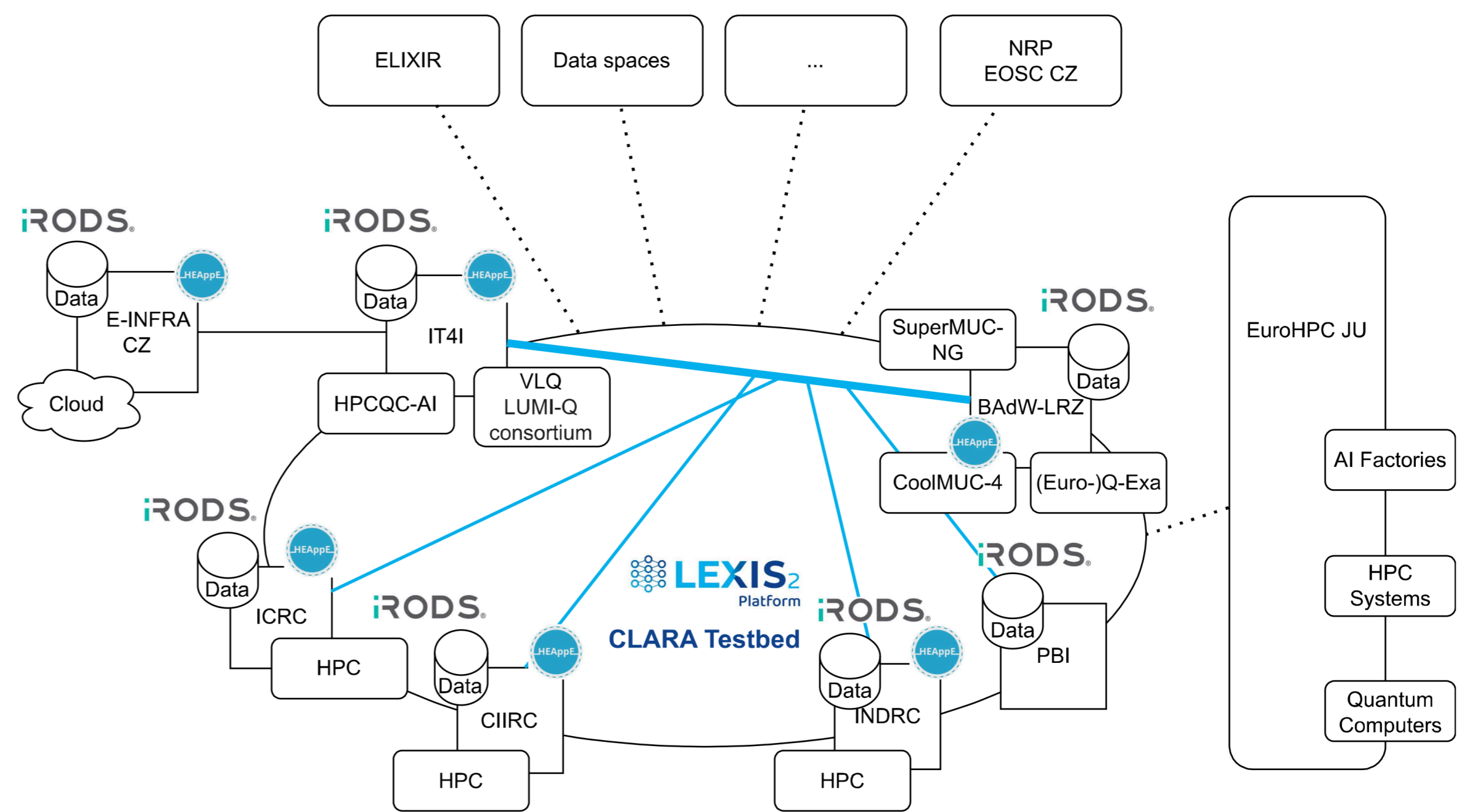

CLARA Testbed

The CLARA Testbed is an advanced distributed **High-Performance and Quantum Computing (HPCQC) platform** designed to advance research in brain science and neurodegenerative disease. By integrating **high-performance computing (HPC), quantum computing (QC), and artificial intelligence (AI)**, it offers a hybrid environment capable of addressing computational challenges that surpass the reach of traditional supercomputing methods.

The testbed is designed for open science, making its computing power and data available to researchers across Europe and beyond.

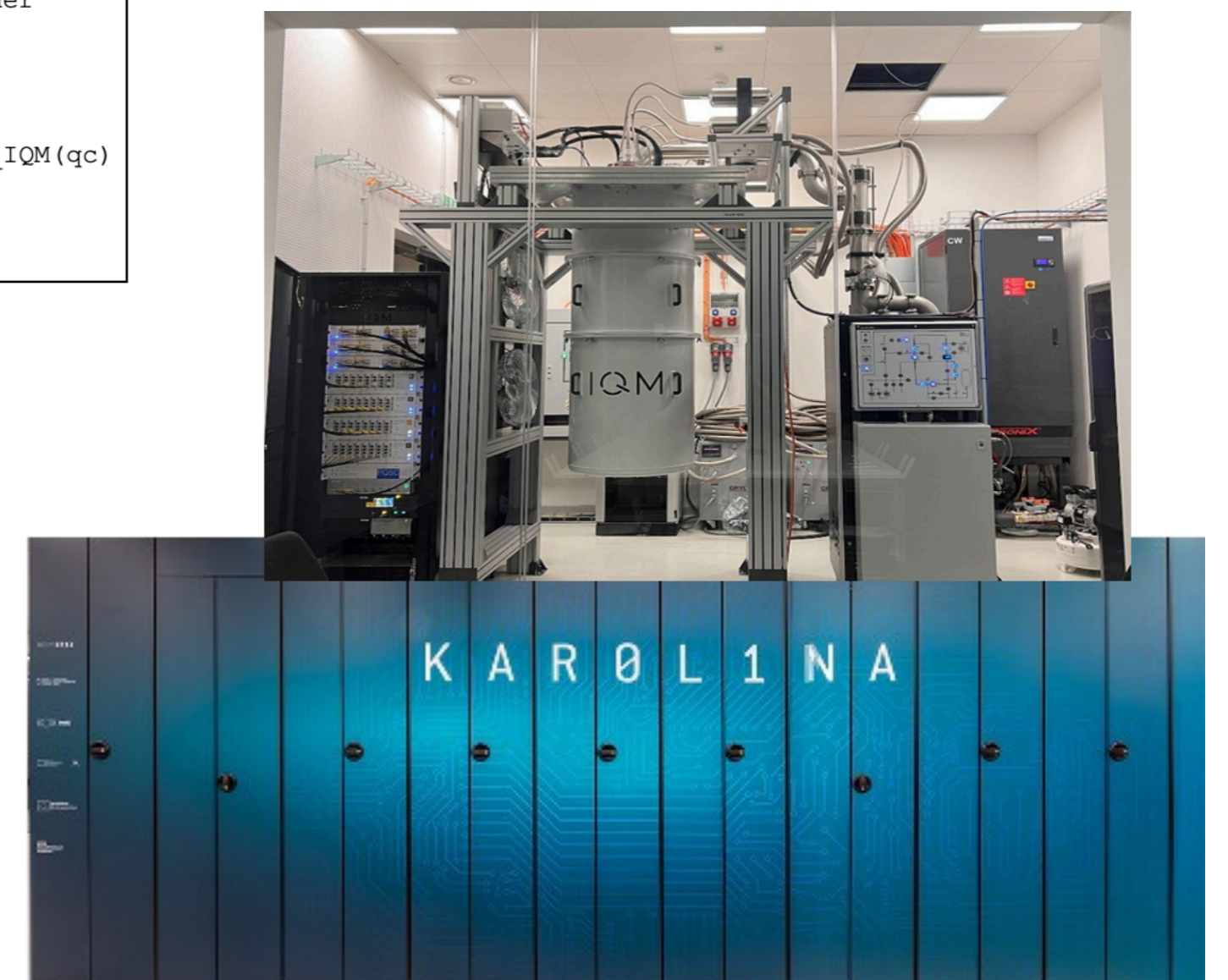
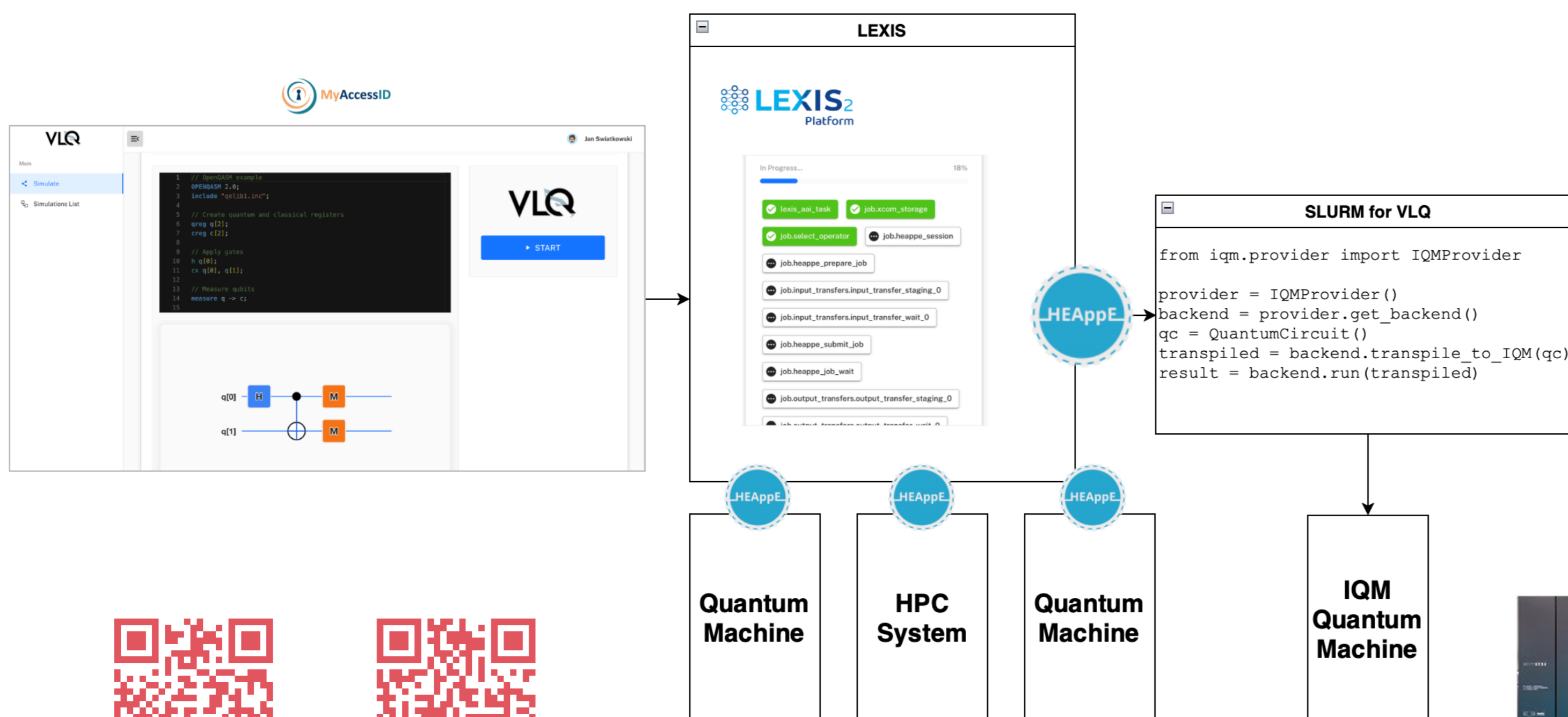

docs.lexis.tech



heappe.eu/docs